



DECKMA GmbH

Decksmaschinen und Automation Vertriebs GmbH

Fon: +49 (0)4105 - 65 60-0 · Fax: +49 (0)4105 - 65 60-25 · Web: www.deckma-gmbh.de · E-Mail: info@deckma-gmbh.de

Deckenleuchte, Einbau / Ceiling Lamp, recessed mounted

DE-Euro 5588-x

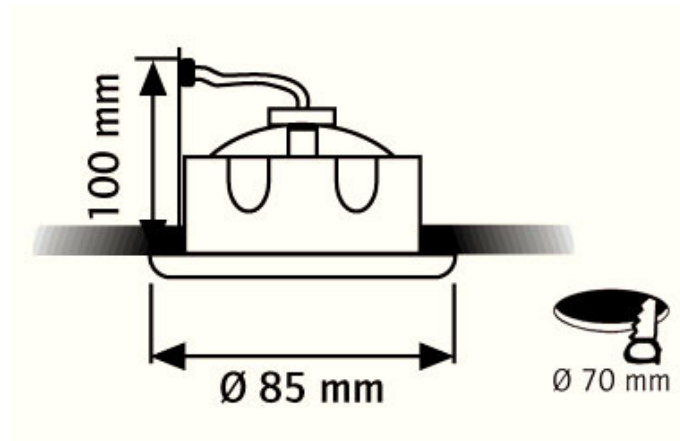

Materialien	Gehäuse aus Druckguss Für eine NV-Halogenlampe mit 50W und GX5,3 Sockel	Materials	Body of die cast Low voltage halogen bulb 50W and GX5.3 socket
Montage	Wand- / Deckeneinbau	Mounting	Wall / ceiling mounted
Schutzart	IP 44	Protection class	IP 44
Abmessungen	Außendurchmesser: 85mm Einbaudurchmesser: 70mm	Dimensions	Outer diameter: 85mm Cut out: 70mm
Gewicht	220g	Weight	220g
Spannung	Abhängig vom Leuchtmittel	Voltage	Depending on lamp

Type	Merkmale	Features	Best. Nr. / Order No.
5588-1	Weiß	White	005-280
5588-3	Gold	Gold	005-281
5588-4	Chrom	Chrome	005-282
5588-5	Eisen gebürstet	Iron brushed	005-283
5588-9	Chrom matt	Chrome opal	005-284